

# DEPRAG

## INDUSTRIAL

Pneumatic Die Grinders for Milling  
Polishers  
Spindle Thread M14  
Model GDS/PA 025, GDS/PA 035



Specifications subject to change without prior notice

**PA 025 - 036 S X**

- X = Lever Valve
- S = Short Design, B = Basic Design
- Speed x 100 [min<sup>-1</sup>]; 36= 3 600 min<sup>-1</sup>
- Power x 10 [W]; 025 = 250 W
- A = Angle 90°; S = Straight Design
- GD = Grinder with Collet
- P = Polisher

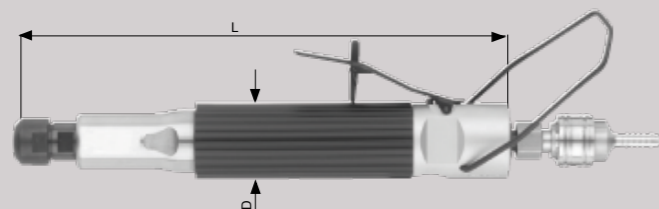

**Specifications**

Design		Pneumatic Die Grinders for Milling, Straight Design,		
Lever Valve	Model Part. No	GDS025-045BX 3150561A	GDS035-045BX 3150571A	GDS035-023BX 3150571B
Speed (no load)	min <sup>-1</sup>	4500	4500	2300
Air consumption	m <sup>3</sup> /min	0,35	0,47	0,47
Max. power output	kW	0,25	0,35	0,35
Diameter	D mm	38	38	38
Lenght	L mm	250	260	260
Weight	kg	0,9	1	1
I.D. of air inlet hose	mm	6	10	10
Air connection		G 1/4 a	G 1/4 a	G 1/4 a

Specifications at 90 psi (6,3 bar)

**Standard Equipment**

Name	Collet Ø 6 mm, plug, quick connect coupler, wrench
------	--

**Optional Accessories**

Name	Part Number
Wire brush (rippled) Ø 50 mm	
Shaft Ø 6 mm	804675
Collet Ø 6 mm	315018
Ø 8 mm	315073
Ø 9 mm	315089
Ø 1/4"	315074
Ø 3/16"	315088
Ø 5/16"	315090
Pressure hose (2 m), exhaust hose (0,75 m)	313179 A (for GDS025-...) 313179 B (for GDS 035-...)

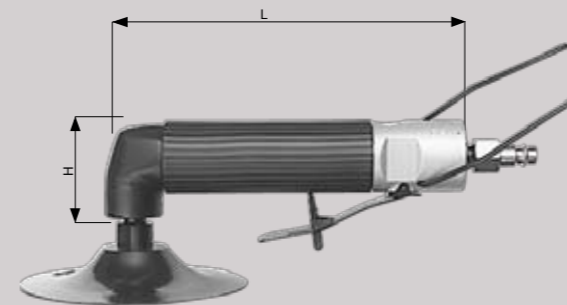

**Specifications**

Design		Polishers				
Lever Valve	Typ Bestell.-Nr.	PA025-036SX 3149172B	PA025-021SX 3149172C	PA025-011SX 3149172D	PA035-036SX 3149181B	PA035-022SX 3149181C
Rubber backing pad	mm	Ø 120	Ø 120	Ø 120	Ø 120	Ø 120
Speed (no load)	min <sup>-1</sup>	3600	2100	1100	3600	2200
Air consumption	m <sup>3</sup> /min	0,35	0,35	0,35	0,47	0,47
Max. power output	kW	0,25	0,25	0,25	0,35	0,35
Thickness	H mm	67	67	67	67	67
Lenght	L mm	189	189	205	200	200
Weight	kg	0,9	0,9	1	1	1
Spindle thread		M14	M14	M14	M14	M14
I.D. of air inlet hose	mm	6	6	6	10	10
Air connection		G 1/4a	G 1/4a	G 1/4a	G 1/4a	G 1/4a

Specifications at 90 psi (6,3 bar)

**Standard Equipment**

Name	Plug, quick connect coupler, wrench
------	-------------------------------------

**Optional Accessories**

Name	Part Number
Rubber backing pad (with flange nut 805187), Ø 120 mm	6075042
T-handle wrench	805080
Fiber disc (for rubber backing pad)	Grain Ø 127
	16 805800
	24 805799
	30 805802
	40 805803
	50 805804
	60 805805
	80 805806
	100 805807
	120 805808
Pressure hose (2 m), exhaust hose (0,75 m)	313179 A (for PA 025-...) 313179 B (for PA 035-...)